

S-60

3-6 ton

GRÚA TORRE TOWER CRANE GRU A TORRE

SAEZ

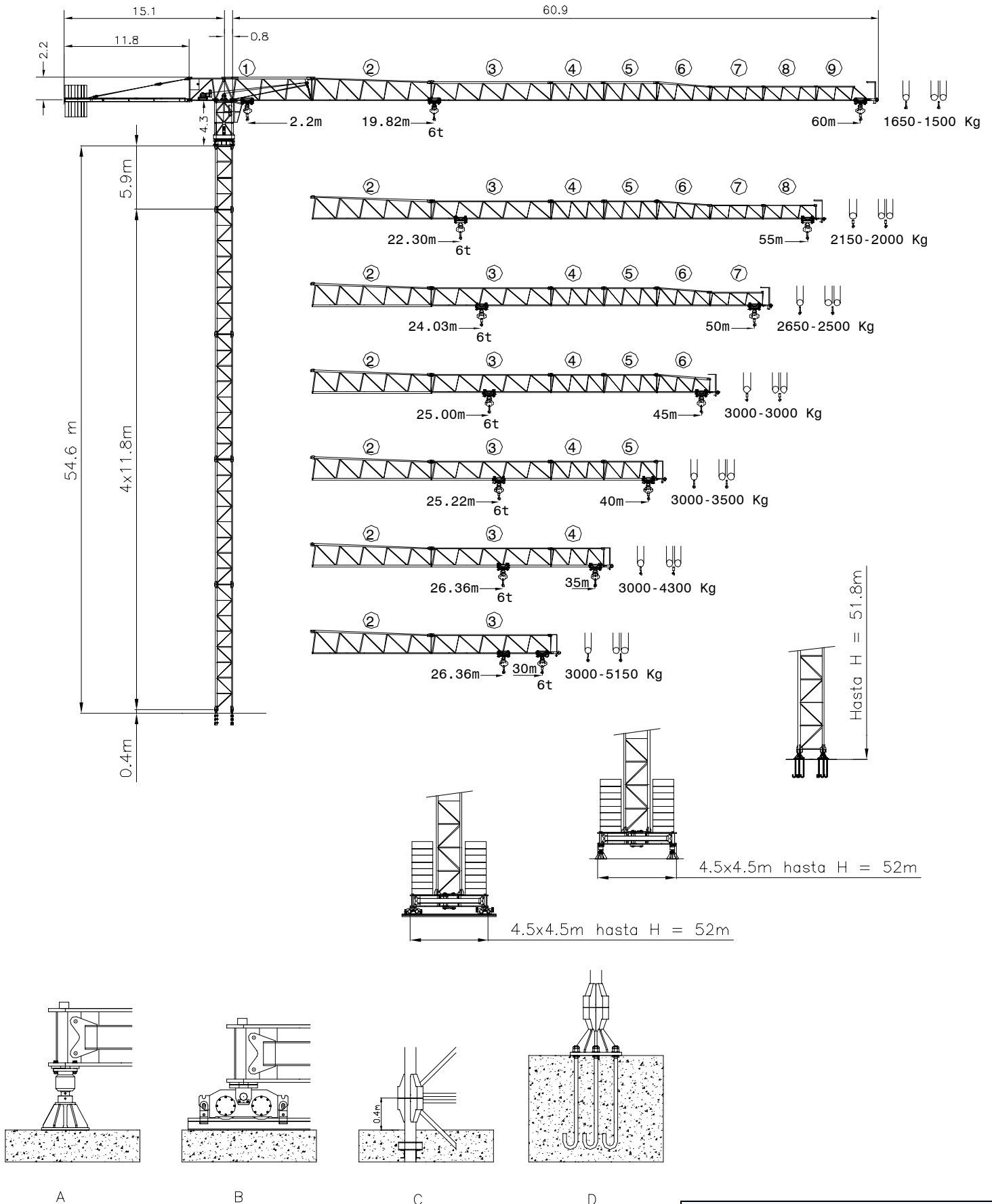

Según UNE 58-101-92 // FEM 1001-87



Cumple directiva 98/37/CE
According to directive 98/37 CE
Compie direttiva 98/37/CE



S-60



3-6 ton



GRÚA TORRE TOWER CRANE GRU A TORRE

SAEZ

		Alcance Radius Sbraccio (m)	CAMPO DE CARGA MAX. Max swl range from to Campo di carico mass 3000 Kg	60	55	50	45	40	35	30	25	20	15	10
3000 kg		60	2.1-37.0	1650	1850	2080	2370	2740	3000	3000	3000	3000	3000	3000
		55	2.1-41.8		2150	2420	2750	3000	3000	3000	3000	3000	3000	3000
		50	2.1-45.1			2650	3000	3000	3000	3000	3000	3000	3000	3000
		45	2.1-45.0				3000	3000	3000	3000	3000	3000	3000	3000
		40	2.1-40.0					3000	3000	3000	3000	3000	3000	3000
		35	2.1-35.0						3000	3000	3000	3000	3000	3000
		30	2.1-30.0							3000	3000	3000	3000	3000
		Alcance Radius Sbraccio (m)	CAMPO DE CARGA MAX. Max swl range from to Campo di carico mass 6000 Kg	60	55	50	45	40	35	30	25	20	15	10
3000 kg		60	2.1-19.8	1500	1700	1930	2200	2590	3060	3690	4580	5940	6000	6000
		55	2.1-22.3		2000	2270	2600	3010	3540	4250	5260	6000	6000	6000
		50	2.1-24.0			2500	2850	3300	3870	4640	5730	6000	6000	6000
		45	2.1-25.0				3000	3460	4060	4860	6000	6000	6000	6000
		40	2.1-25.2					3500	4100	4910	6000	6000	6000	6000
		35	2.1-26.2						4300	5140	6000	6000	6000	6000
		30	2.1-26.4							5150	6000	6000	6000	6000
6000 kg		60	2.1-19.8	1500	1700	1930	2200	2590	3060	3690	4580	5940	6000	6000
		55	2.1-22.3		2000	2270	2600	3010	3540	4250	5260	6000	6000	6000
		50	2.1-24.0			2500	2850	3300	3870	4640	5730	6000	6000	6000
		45	2.1-25.0				3000	3460	4060	4860	6000	6000	6000	6000
		40	2.1-25.2					3500	4100	4910	6000	6000	6000	6000
		35	2.1-26.2						4300	5140	6000	6000	6000	6000
		30	2.1-26.4							5150	6000	6000	6000	6000



CARGA/VELOCIDAD (kg/m/min) LOAD/SPEED (Kg/m/min)/ CARICO/ VELOCITA' (Kg/m/min)	
Potencia/Power/Potenza	33 Hp (24 Kw) 3 vel
	3000 kg - 8 m/min
	3000 kg - 37 m/min
	1500 kg - 74 m/min
	6000 kg - 4 m/min
	6000 kg - 18.5 m/min
	3000 kg - 37 m/min

MECANISMOS MECANISM / MECANISMI		
		
0.3 - 0.6 - 0.9 rpm	30 / 60 m/min	12 / 24 m/min
2 x 65 Nm	3Kw	4 x 3Kw

*** CARGA/VELOCIDAD (kg/m/min) LOAD/SPEED (Kg/m/min)/ CARICO/ VELOCITA' (Kg/m/min)	
Potencia / Power / Potenza	33 Hp (24 Kw) VF
	3000 kg - 0 ÷ 45 m/min
	2500 kg - 0 ÷ 50 m/min
	2000 kg - 0 ÷ 60 m/min
	1250 kg - 0 ÷ 100 m/min
	6000 kg - 0 ÷ 22.5 m/min
	5000 kg - 0 ÷ 25 m/min
	4000 kg - 0 ÷ 30 m/min
	2500 kg - 0 ÷ 50 m/min

Alcance / Radius / Sbraccio		60	55	50	45	40	35	30
Contrapeso Aéreo Counterweight Air Contrappeso aereo	Tipo	A	A	A B	A B	A B	A B	A B
	Nº	7	7	6 1	5 2	5 1	4 2	4 1
	Kgs	16200	16200	15200	14300	12900	12000	10600

Lastre de la Base Base Ballast Blocks Zavorra alla base		H (m)	14.3	20.2	26.1	32.0	37.9	45.8	49.7
	Ton	48	60	72	84	96	120	120	

*** CARGA/VELOCIDAD (kg/m/min) LOAD/SPEED (Kg/m/min)/ CARICO/ VELOCITA' (Kg/m/min)	
Potencia/Power/Potenza	45 Hp (33Kw) VF
	3000 kg - 0 ÷ 60 m/min
	2000 kg - 0 ÷ 80 m/min
	1250 kg - 0 ÷ 120 m/min
	6000 kg - 0 ÷ 30 m/min
	4000 kg - 0 ÷ 40 m/min
	2500 kg - 0 ÷ 60m/min

*** OPCIONAL
OPTIONAL
OPZIONALE

PESO DE CONSTRUCCIÓN APROXIMADO DEAD WEIGHT APROX. / PESO DI COSTRUZIONE APPROSSIMATO		44.000 Kg
Potencia Requerida y Conductores Required Power and Conductors Potenza elettrica necessaria e conduttori	Con Elevación 24 Kw / With elevation 24 Kw / Con sollevamento 24 Kw	
	44 KVA - 380 V - 50 Hz	
	25 m	50 m
	4x25mm ²	4x35mm ²
		100 m
		4x35mm ²

S-60

3-6 ton

GRÚA TORRE TOWER CRANE GRU A TORRE

SAEZ

COMPOSICIÓN DE TORRE / TOWER COMPOSITION / STRUTTURA DELLA TORRE

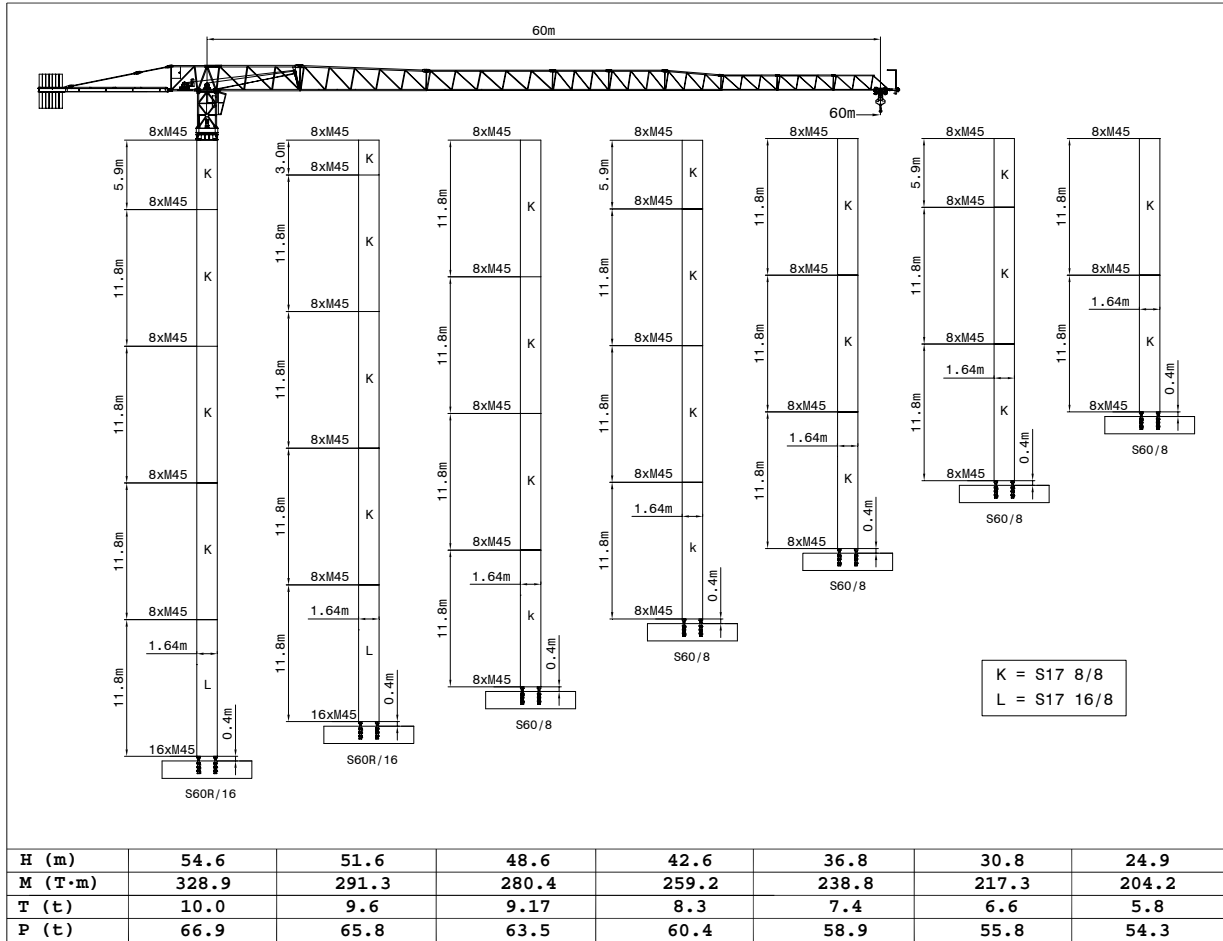

MONTAJE HIDRÁULICO / HYDRAULIC ASSEMBLY / MONTAGGIO IDRAULICO

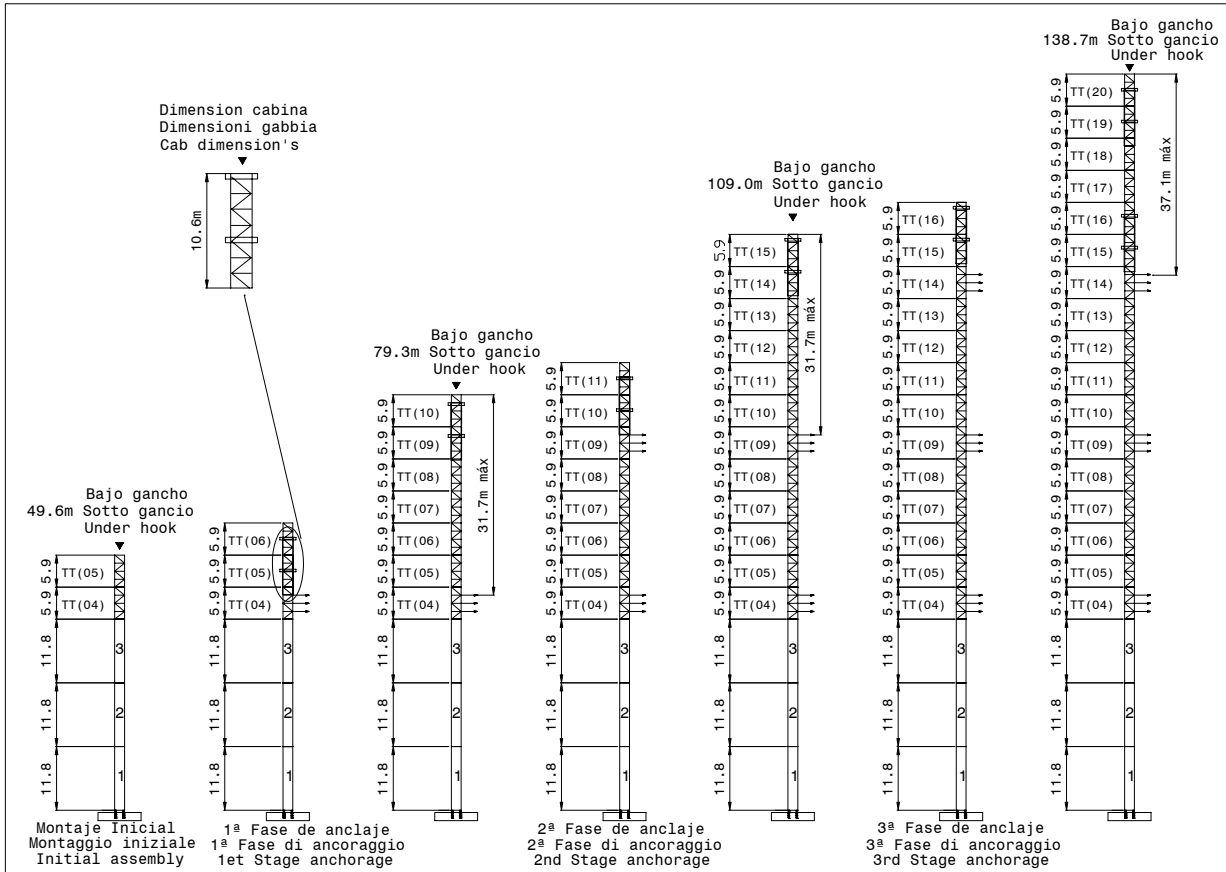





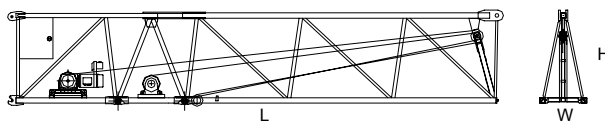
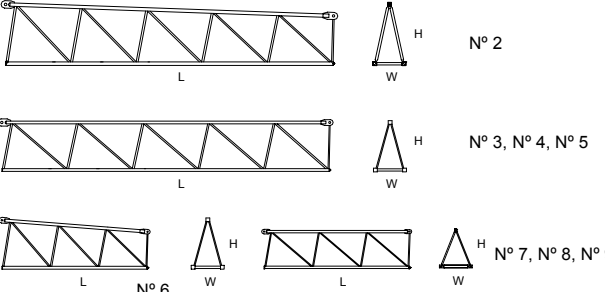
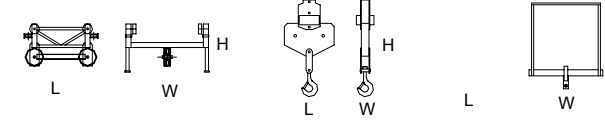
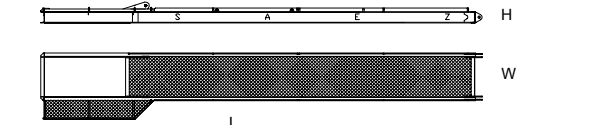
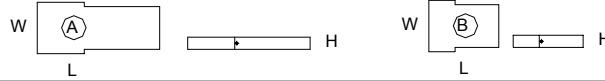
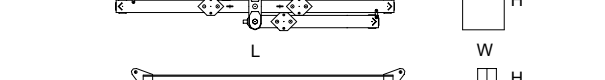

S-60

3-6 ton

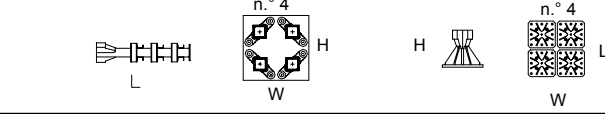
GRÚA TORRE TOWER CRANE GRU A TORRE

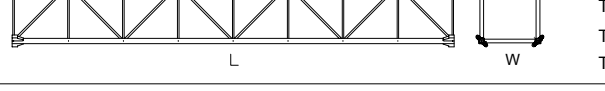
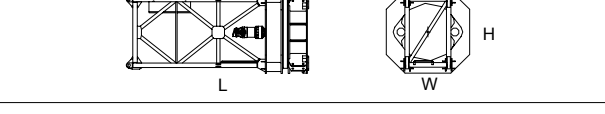
SAEZ

PESO Y DIMENSIONES DE LOS ELEMENTOS DE LA GRUA WEIGH AND DIMENSION OF THE CRANE COMPONENTS / PESO E DIMENSIONI DEI ELEMENTI DELLA GRU		L (m.)	W (m.)	H (m.)	Peso (Kg.)
ELEMENTO DE PLUMA N° 1 JIB ELEMENT N° 1 ELEMENTO DI BRACCIO		11,90	1,25	2,30	5500
ELEMENTOS DE PLUMA DEL N° 2 AL N° 9 JIB ELEMENTS FROM N° 2 TO N° 9 ELEMENTO DI TORRE DI 2°- N°9		2 3 4 5 6 7 8 9	11,60 11,60 5,30 5,30 5,30 5,30 5,30 5,15	1,13 1,13 1,13 1,13 1,13 1,13 1,45 1,40	2145 1676 596 516 444 410 320 238
CARRO Y GANCIO Y PUNTA TROLLEY - HOOK - JIB END CARRELLO, GANCIO E PUNTA		1,20 0,80 0,80	1,35 0,15 1,20	0,80 1,50 1,40	228 267 75
CONTRAPLUMA COMPLETA COUNTERJIB COMPLETE CONTROBRACCIO		11,80	1,80	0,60	2840
BLOQUE DE CONTRAPESO COUNTERWEIGHT BLOCKS BLOCCO DI CONTRAPPESO		2,95 1,70	1,25 1,25	0,30 0,30	2300 1400
BASE CRUCIFORME 4,5 X 4,5 BASE CHASSIS 4,5 X 4,5 CARRO BASE 4,5 X 4,5		6,70	1,10	1,20	5900
VIGAS AUXIL. DE BASE BASE CHASSIS SEC. BEAMS TRAVI DI CONGIUNZIONE		4,40	0,30	0,55	450
BLOQUE LASTRE DE BASE BASE BALLAST BLOCKS BLOCCO DI ZAVORRA ALLA BASE		4,40	0,25	1,20	3000
EL. EMPOTRE BASE EMB. ELEMENTS EL ANNEGARE EL. ATORNILLADOS BASE TIED ELEMENTS EL RECUPERABILE		1,50 1,35	0,70 1,35	0,70 0,60	750 1150
NIVELADORES LEVELLING FEET PIEDI REGOLABE TRASLACION TRAVELLING BOGIES TRASLAZIONE		1,20 1,15	1,20 1,25	0,90 0,45	1150 800
ELEMENTO DE TORRE TL16 TOWER ELEMENT TL16 ELEMENTO DI TORRE		TL16 TR16 TS16 TC16	11,80 11,80 5,95 3,00	1,85 1,85 1,85 1,85	4600 5740 2450 1380
UNIDAD DE ROTACION SLEWING UNIT COMPLETE ROTAZIONE		4,40	2,00	2,00	6400
CABINA Y SUPPORTO OP. CABIN WITH SUPPORT CABINA E SUPPORTO		3,00	1,15	2,35	500

Sistemas Forza, S.L. Ctra. de Benijaán, Km. 5 – Benijaán – MURCIA (España)
Tlf.: +34 968 82 08 62 / 66 – Fax. +34 968 82 48 57
E-mail. forza@forzasl.com
www.forzasl.com

Gruas SÁEZ se reserva el derecho a modificaciones sin previo aviso.
Subject to modifications by Gruas SÁEZ, without previous warning.
Il fabbricante si riserva il diritto di fare qualunque modifica senza preavviso.